

MS200 and MS202

Portable and Permanent Monorail Scales

Standard Features

- 8 inch long live rail designed to weigh one trolley at a time
- 750 lb x .5 lb resolution in both portable and permanent models
- Available for rail sizes 3/8 in x 2 1/2 in or 1/2 in x 2 1/2 in
- Requires less than 41 inches of straight rail to install (14 inch between rail hangers for permanent model)
- Zinc-plated, steel construction
- High accuracy, stainless steel load cell
- 25 ft of load cell cable for flexible installation
- Slightly recessed live rail for the trolley roller provides stable weighments

Specifications

MS200/MS202 Construction:

Zinc-plated steel construction, stainless steel hardware

Load Cell Construction:

Stainless steel

Bridge Resistance:

350 ohms nominal

Rated Output:

2 mV/V

Nonlinearity:

0.03% full scale

Approvals:

NTEP CC 90-003, Class III, nmax 1500

Part Number/Price

PART #	DESCRIPTION	WEIGHT	PRICE
19743*	MS200HB, NTEP Certified portable	38 lb	Consult
19744*	MS202HB-3/8 in, NTEP Certified permanent	38 lb	Consult
19745*	MS202HB-1/2 in, NTEP Certified permanent	38 lb	Consult

*Scale only, indicator not included

Options/Accessories

PART #	DESCRIPTION	PRICE
16984	Additional operating manual	Consult

NOTE: If scale is not going to be moved to different locations, the MS-202 permanent model is recommended for easier transfer of the load.



APPROVALS

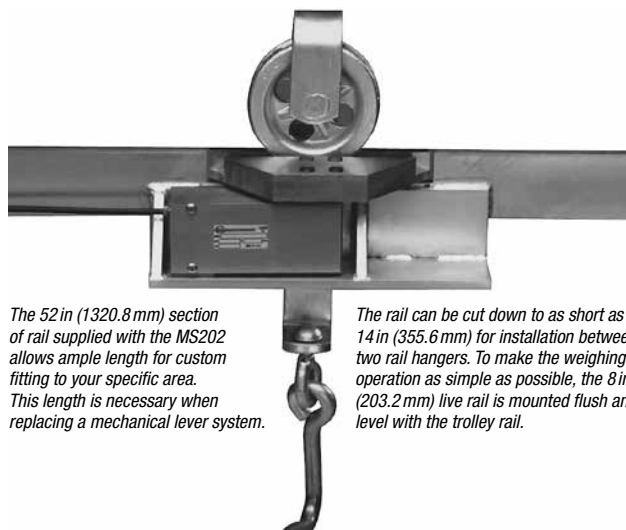

The 52 in (1320.8 mm) section of rail supplied with the MS202 allows ample length for custom fitting to your specific area. This length is necessary when replacing a mechanical lever system.

The rail can be cut down to as short as 14 in (355.6 mm) for installation between two rail hangers. To make the weighing operation as simple as possible, the 8 in (203.2 mm) live rail is mounted flush and level with the trolley rail.

MS202 Permanent Monorail Scale

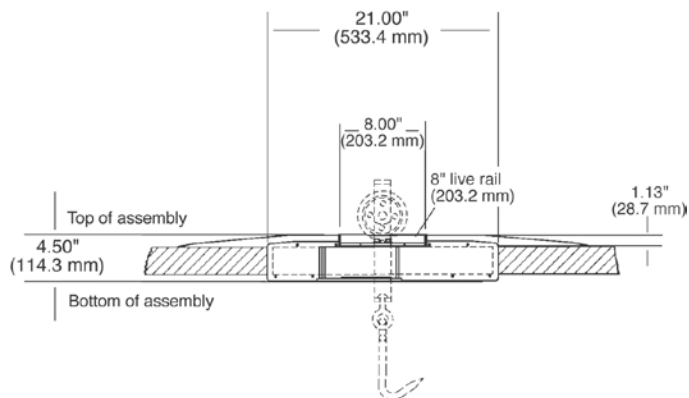

MS200/MS202 Dimensions